

Planta de localização escala 1:50

P2=P3=P4=P5=P6=P7=P8=P10=P11=P12P9

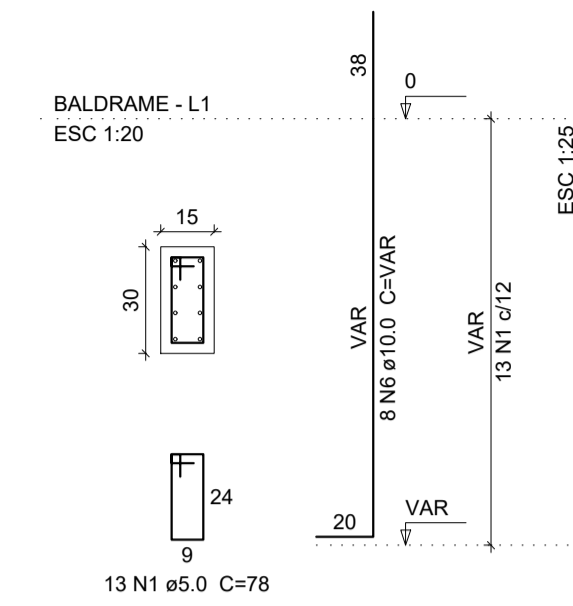

S2=S3=S4=S5=S6=S7=S8=S9=S10=S11=S12

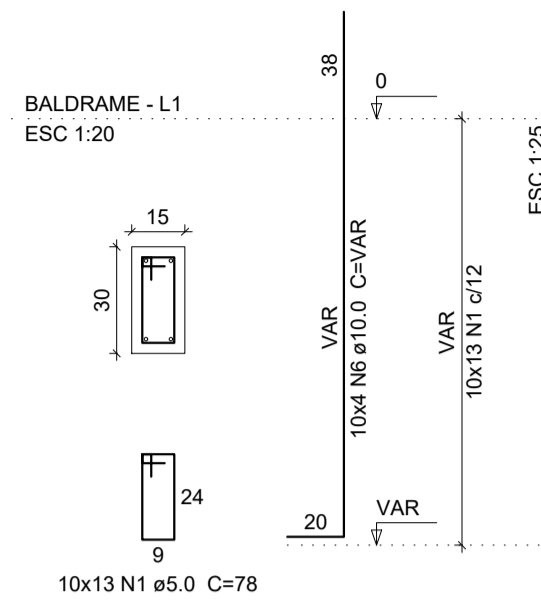
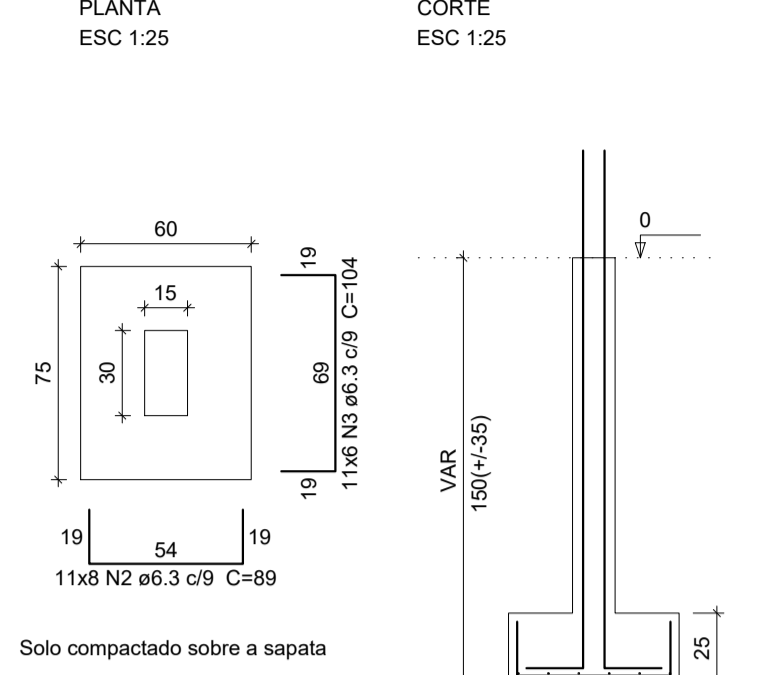

P1

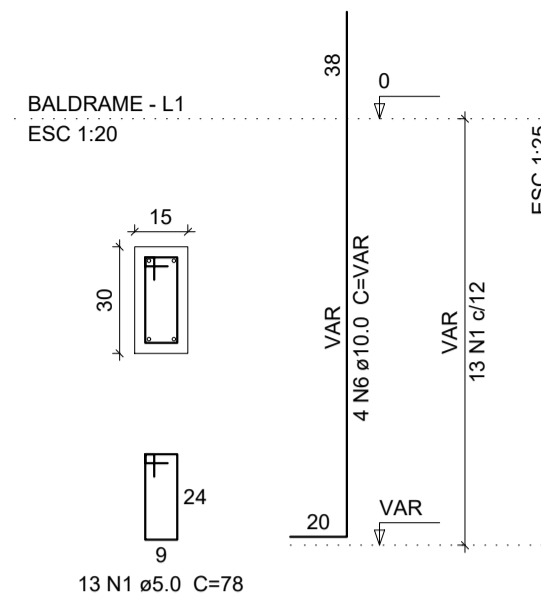

S1

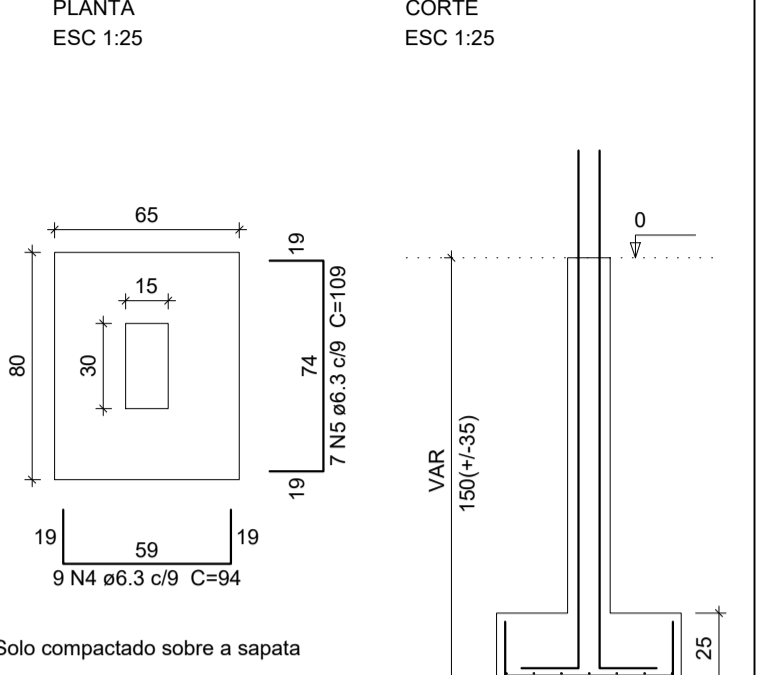

Nome	Seção (cm)	X (cm)	Y (cm)	Pilar		Fundação								
				Carga Máx. (tf)	Carga Min. (tf)	Mx (kgf.m)	My (kgf.m)	Fx (tf)	Fy (tf)	Lado B (cm)	Lado H (cm)	h0 / ha (cm)	h1 / hb (cm)	df (cm)
P1	15x30	7.50	514.95	5.2	4.6	600	300	0.4	0.9	65	80	25	25	150
P2	15x30	422.60	514.95	4.9	3.4	400	100	0.2	0.2	60	75	25	25	150
P3	15x30	732.55	522.45	3.5	2.6	200	300	0.3	0.2	60	75	25	25	150
P4	15x30	1045.10	522.45	2.5	1.8	200	200	0.3	0.2	60	75	25	25	150
P5	15x30	277.50	364.95	3.4	2.8	300	200	0.4	0.4	60	75	25	25	150
P6	15x30	430.05	372.55	4.4	3.4	300	300	0.3	0.3	60	75	25	25	150
P7	15x30	737.50	365.05	5.0	4.3	400	100	0.1	0.5	60	75	25	25	150
P8	15x30	1045.10	372.55	4.2	3.6	300	200	0.3	0.4	60	75	25	25	150
P9	15x30	15.00	7.50	4.5	4.1	400	300	0.4	0.7	60	75	25	25	150
P10	15x30	422.55	15.00	5.1	4.7	300	200	0.2	0.3	60	75	25	25	150
P11	15x30	737.50	15.00	4.7	4.2	300	100	0.1	0.3	60	75	25	25	150
P12	15x30	1052.60	15.00	3.3	2.9	300	200	0.3	0.4	60	75	25	25	150

Relação do aço

AÇO	N	DIAM (mm)	QUANT (Barras)	UNIT (cm)	C.TOTAL (cm)
CA60	1	5.0	156	78	12168
CA50	2	6.3	88	89	7832
	3	6.3	66	104	6864
	4	6.3	9	94	846
	5	6.3	7	109	763
	6	10.0	52	VAR	VAR

Resumo do aço

AÇO	DIAM (mm)	C.TOTAL (m)	PESO (kg)
CA50	6.3	163.1	39.9
CA60	5.0	121.7	18.8
PESO TOTAL (kg)			105
CA50			105
CA60			18.8

Volume de concreto (C-25) = 2.18 m³
Área de forma = 24.35 m²

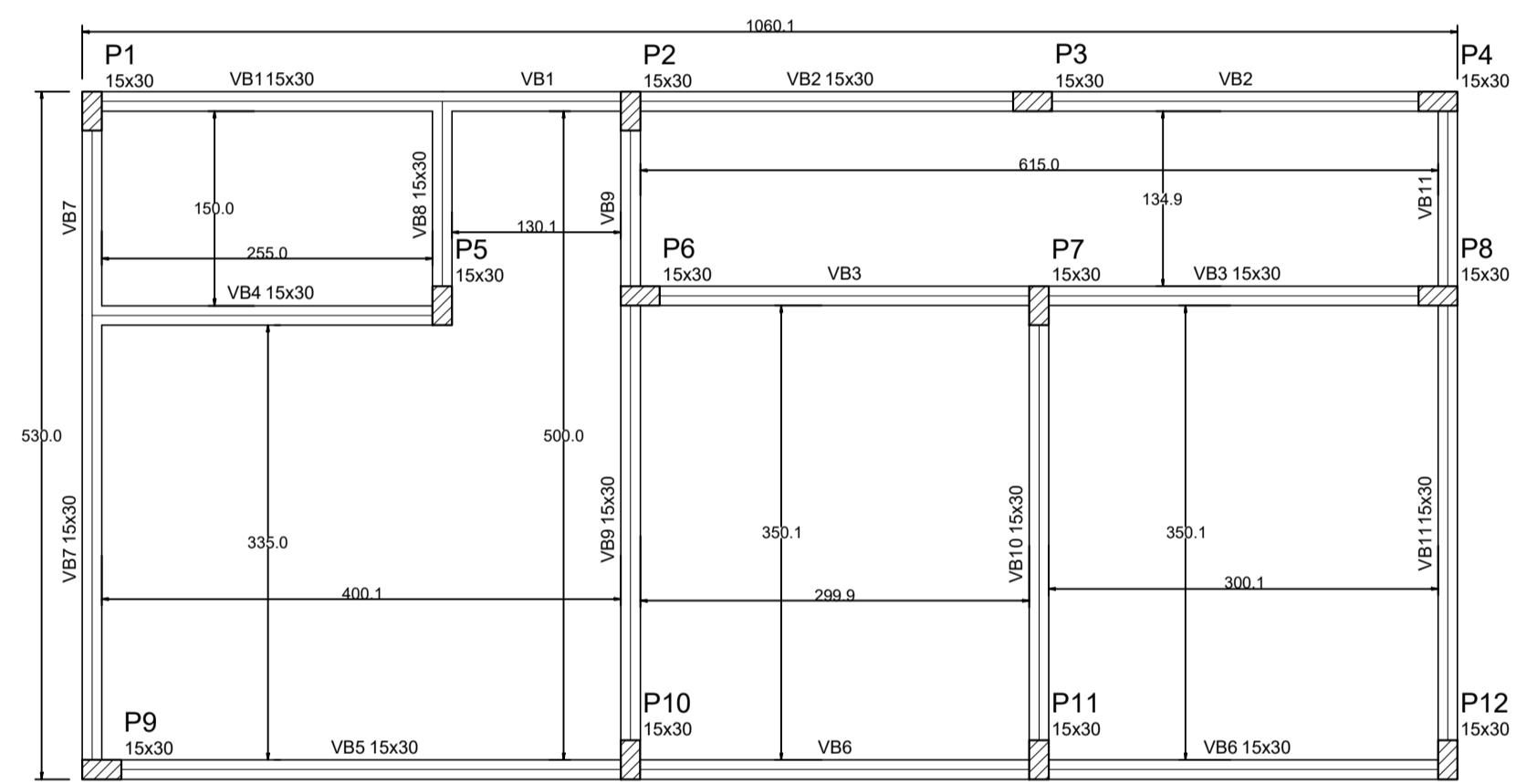

Forma do pavimento Baldrame escala 1:50

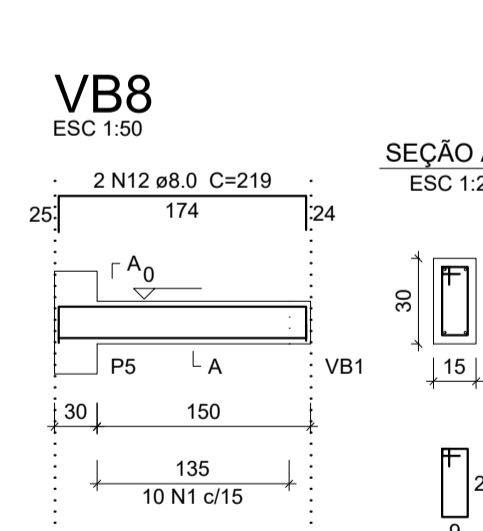
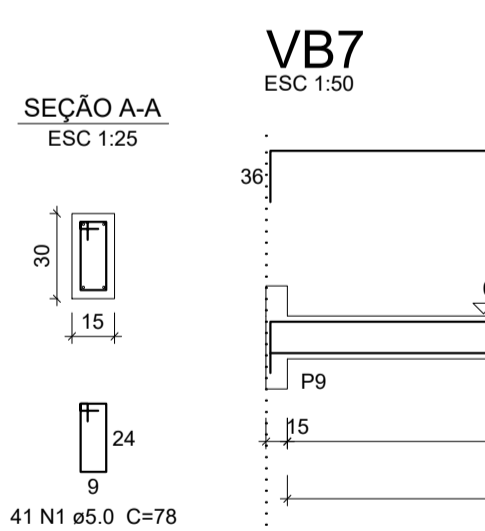
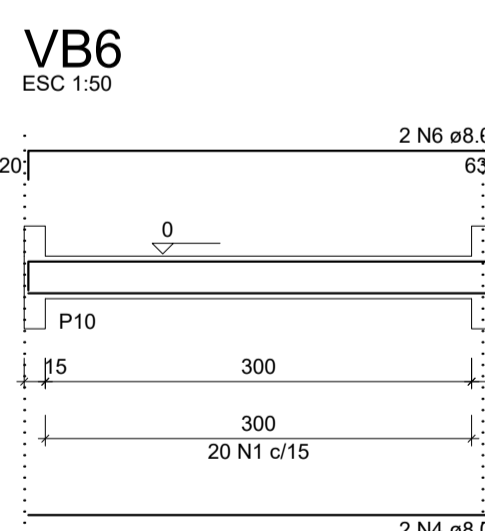
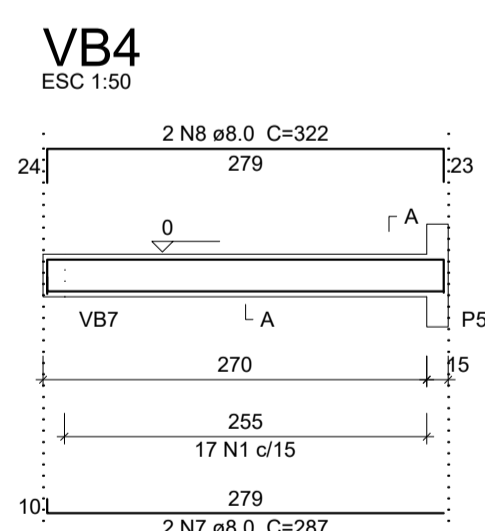
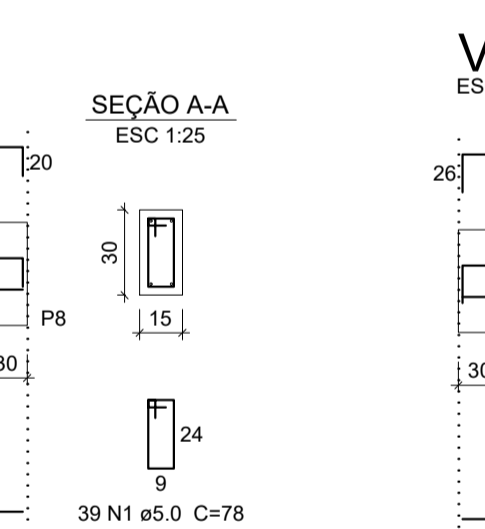
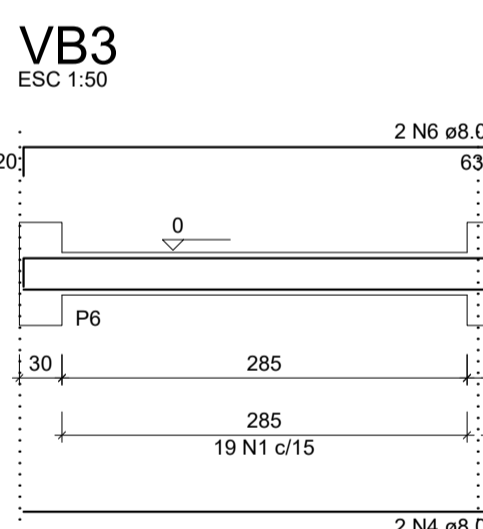
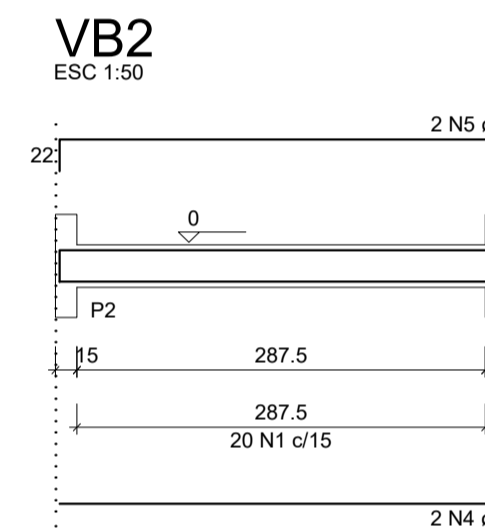
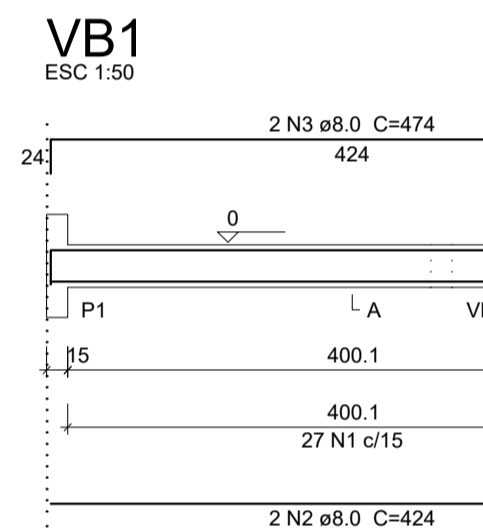

Relação do aço

AÇO	N	DIAM (mm)	QUANT (Barras)	UNIT (cm)	C.TOTAL (cm)
CA60	1	5.0	317	78	24726
CA50	2	8.0	4	424	1696
	3	8.0	2	474	948
	4	8.0	6	639	3834
	5	8.0	2	677	1354
	6	8.0	4	675	2700
	7	8.0	2	287	574
	8	8.0	2	322	644
	9	8.0	2	474	948
	10	8.0	4	524	2096
	11	8.0	2	182	364
	12	8.0	2	219	438
	13	8.0	2	562	1124
	14	8.0	2	374	748
	15	8.0	2	414	828
	16	8.0	2	532	1064
	17	8.0	2	563	1126
	18	10.0	1	159	159
	19	10.0	2	589	1178

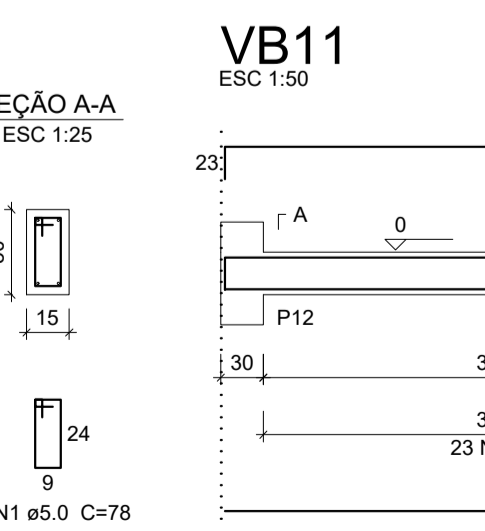
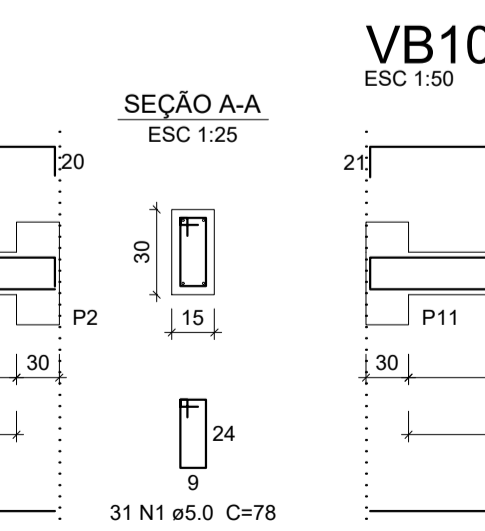
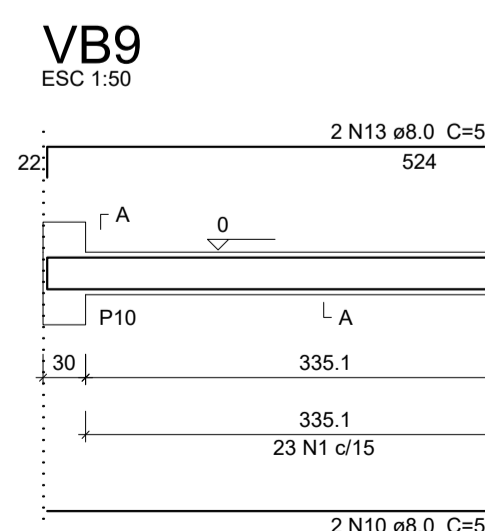

Nome	Seção (cm)	Elevação (cm)	Nível (cm)
VB1	15x30	0	0
VB2	15x30	0	0
VB3	15x30	0	0
VB4	15x30	0	0
VB5	15x30	0	0
VB6	15x30	0	0
VB7	15x30	0	0
VB8	15x30	0	0
VB9	15x30	0	0
VB10	15x30	0	0
VB11	15x30	0	0

Resumo do aço

AÇO	DIAM (mm)	C.TOTAL (m)	PESO (kg)
CA50	8.0	204.9	80.8
	10.0	13.4	8.2
CA60	5.0	247.3	38.1
PESO TOTAL (kg)			127.1
CA50			89.1
CA60			38.1

Volume de concreto (C-25) = 2.35 m³
Área de forma = 39.23 m²

PREFEITURA:

PROJETO ESTRUTURAL

OBRA: Ampliação da Creche Abrosia Maria de Jesus
 PROPRIETÁRIO: Prefeitura Municipal de Carmolândia
 CIDADE: Carmolândia - TO
 TIPO DA OBRA: PÚBLICA

R.T. - PROJETO:

Engenheiro Civil Bruno Correio Santos - CREA: 201065/D-TO

PROPRIETÁRIO: PREFEITURA MUNICIPAL DE CARMOLÂNDIA
 CNPJ: 25.063.868/0001-61

CONTATO: (63) 98440-6047

PARA USO DO REQUERENTE

QUADRO DE ÁREAS: VERIFICAR PROJETO ARQUITETONICO

CONTEUDO DA FOLHA:
 • PLANTA DE LOCAÇÃO
 • RESUMO DE AÇO
 • DETALHAMENTO SAPATAS
 • DETALHAMENTO VIGAS BALDRAME
 • FORMA VIGAS BALDRAME

ENDEREÇO: CRECHE AMBROSIA MARIA DE JESUS
 BAIRRO: CENTRO
 ESCALA: INDICADA
 DATA: OUTUBRO /2019

DESENHO: ESTRUT. FOLHA NÚMERO: BRUNO 01-02